

The mesytec **MPR-Series** provides a set of state of the art multichannel preamplifier modules specially designed for single or double sided multi strip silicon detectors. The MPR series can be used as stand alone modules and can also easily be combined with the mesytec MSCF-16 or STM-16 shaping-/timing filter/ discriminator module.

## Features:

- 16 / 32 / 64 channel compact module
- Sensitivity switch, factor 5
- ESD input protection
- Differential output 100  $\Omega$  or
- MPR-16L with Lemo output connectors
- Pulser input
- Bias voltage up to  $\pm 400$  V
- PCB module available for vacuum use



## Schematics:

(for MPR-16)

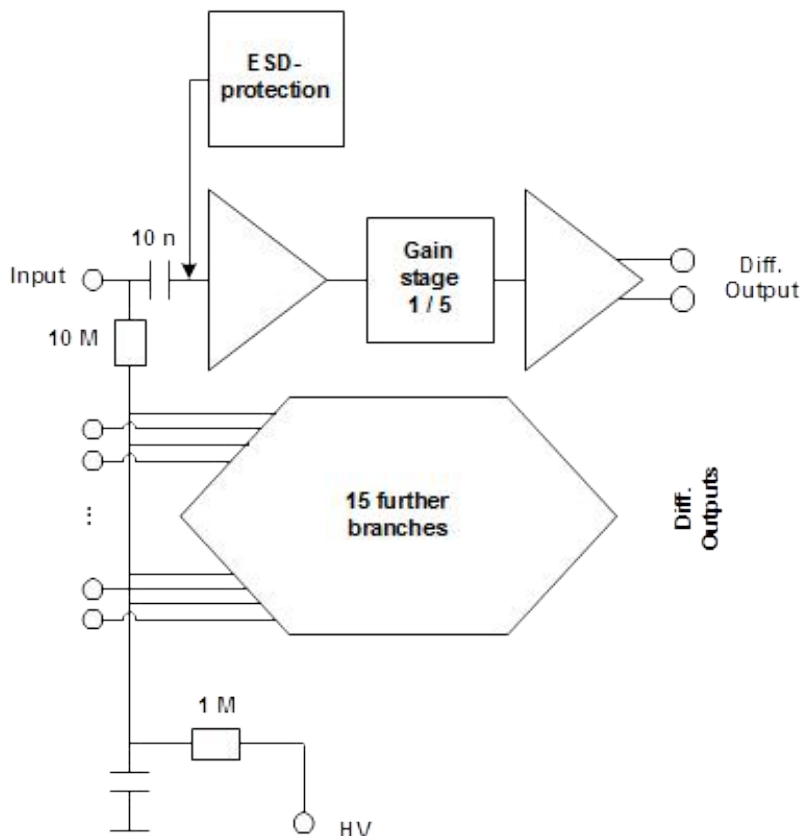

## Technical Data

### Energy ranges

The MPR series provides a switch to amplify the output signal by a factor of 5. This helps to provide large output signals even at low charge depositions and thus provides good noise immunity.

### Input stage

- Input connector(s): SubD25 female connector (for a 16 channel unit)
- Pin assignment:

Function	connector	Function	connector
Sig-gnd	1,2,7,12,13,14,15,25	Cha 9	19
Cha 1	11	Cha 10	6
Cha 2	23	Cha 11	18
Cha 3	10	Cha 12	5
Cha 4	22	Cha 13	17
Cha 5	9	Cha 14	4
Cha 6	21	Cha 15	16
Cha 7	8	Cha 16	3
Cha 8	20	guardring	24

- Positive and negative charge can be amplified equally.
- The guardring output (24) is connected via R-C-R filter (100 k $\Omega$ , 10 nF, 100 k $\Omega$ ) to the common detector bias input.

### Output stage

- Differential output for twisted pair 34 pin male header connector.
- Output amplitude: 0 to  $\pm 1$  V
- (max swing  $\pm 4$  V)
- Pin assignment of output connector:  
pin 1, 2 channel 1, pin 3, 4 channel 2.....  
pin 33, 34 output ground

### Rise and decay time

Standard decay times is about 25  $\mu$ s, others on request. Risetime is 12 ns for 0 pF input capacity.

### Noise

For the MPR-16 series, power modes can be selected by a jumper on the PCB. High Power mode

reduces noise, while low Power mode may be useful for in vacuum use.

power mode	shaping time	MPR16-25 MPR16-100
	$\sigma$ / FWHM [ $\mu$ s]	noise [keV]
LP	0.4 / 1	(5 + 0.06/pF)
	1 / 2.5	(4 + 0.04/pF)
HP	0.4 / 1	(5 + 0.04/pF)
	1 / 2.5	(4 + 0.027/pF)

### Pulser input

The pulser is internally distributed to individual charge termination capacities. Tolerances  $\pm 10$  %.

MPR16-25	MPR16-100	MPR16-500	MPR16-1500
0.78 pF 17 MeV/V	0.78 pF 17 MeV/V	2.4 pF 50 MeV/V	10.2 pF 230 MeV/V

### Detector bias input

- Lemo connector
- Maximum voltage  $\pm 400$  V
- When not connected, detector side must be on ground level: terminate bias input with 50  $\Omega$  Lemo terminator.

### Ground connections

- Ground screws on front and rear side
- There are two different ground connections: input and output ground.
- Input ground is connected to the vacuum vessel if the setup is not isolated (ie. isolated flange).
- In critical environment the output ground can be connected to the NIM electronics.

### Power connector

SubD-9 connector:

- 1, 2 = gnd
- 3 = +6 V
- 4 = +12 V
- 5 = -6 V
- 9 = -12V (here not used)
- 8 = Range (0V / 5V), NC if not used\*
- 6, 7 = NC (not connected)

(\* a voltage level of 0 V / 5 V applied to pin 8 switches into lo / hi energy range and overrides the panel switch.)

**Pinout of on board power connector for PCB version**

- gnd : 1,3,10,11,12
- +12 V : 7
- +6 V : 5
- -6 V : 9
- LED+ : 13 ("power ok" LED)
- LED- : 14

For Revision V70 and higher:

- range: 6 (leave open if switch is used)
- high gain → connect to gnd
- low gain → connect to +3 V...+6 V

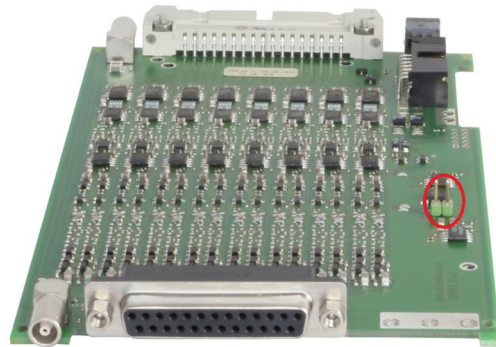

On the right side the power select jumper can be seen. When open, high power is selected (default at delivery).

**Power consumption for 16 channels**

Parameter	MPR16-25 MPR16-100	MPR16-500 MPR16-2500
	current [mA]	
LP/HP +6 V	50	50
LP/HP -6 V	50	50
LP +12 V	40	-
HP +12 V	80	40
total power LP-mode	1.1 W	-
total power HP-mode	1.6 W	1.1 W

LP = low power mode, HP = high power mode

**Cooling**

Due to the low power consumption cooling is not necessary.

For **in vacuum use**, select low power mode if possible. The power of a single PCB can be dissipated without problems. If several PCBs are densely packed, heat conducting metal shields should be placed in between the PCBs.

Avoid to warm up silicon detectors by the dissipated power.

**Dimensions**

- Length : 173 mm (without connectors)
- Width : 105 mm
- Height : 46 mm (MPR-16)  
67 mm (MPR-32)  
92 mm (MPR-64)

**Mounted as MPR-32:**



**Mounted as MPR-64:**